

# ELASTISCH DICHTENDER ABSPERRSCHIEBER ECOVALVE™ FLANSCHENDE F4

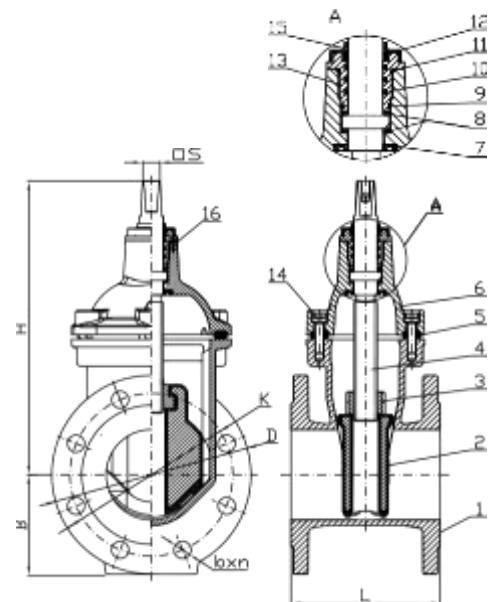

DN 40 - DN 300

Nr.	Name des Teils	Material
1	Gehäuse	Sphäroguss EN-GJS-500-7
2	Keil	D.I., EPDM-gekapselt EN-GJS-400-18/ EN-GJS-500-7
3	Keilmutter	Aluminiumbronze CuAl10Ni5Fe4 / H.T. entzinkungsbeständig Messing
4	Stiel	Rostfreier Stahl X20Cr13 / 1.4021 / 420
5	Ventildeckeldichtung	Elastomer EPDM
6	Ventildeckel	Sphäroguss EN-GJS-500-7
7	Hauptdichtung	Elastomer EPDM
8	Unterlegscheibe	Kunststoff PTFE
9	O-Ringdichtung	Elastomer EPDM
10	O-Ringdichtung	Elastomer EPDM
11	O-Ringdichtung	Elastomer EPDM
12	Staubdichtung	Elastomer NBR
13	Stopfbuchse	Messing
14	Ventildeckelschrauben	Rostfreier Stahl A2-70
15	Ventildeckel-Staubdichtung	Elastomer NBR
16	Sicherheitsschraube	Rostfreier Stahl A2-70



## Abmessungen:

DN	40	50	65	80	100	125	150	200	250	300	
F4	PN10	AD0351	AD0352	AD0353	AD0354	AD0355	AD0356	AD0357	AD0361	AD0362	AD0363
	PN16								AD0358	AD0359	AD0360
L	140	150	170	180	190	200	210	230	250	270	
H	205	218	255	277	325	355	395	482	572	662	
B	70	75	85	95	102	120	134	165	196	225	
K PN16 / PN10	110	125	145	160	180	210	240	295	355 / 350	410 / 400	
b×n PN16 / PN10	19×4	19×4	19×4	19×8	19×8	19×8	23×8	23×12 / 23×8	27×12 / 23×12	27×12 / 23×12	
D	150	165	185	200	220	250	285	340	405	460	
Stiel oben quadratisch □S	14	14	17	17	19	19	19	24	27	27	
Gewicht [kg]	8,5	9,5	11,5	13,0	17,5	24,0	31,5	54,0	76,5	109,5	