

HANDRÄDER FÜR WASSERVENTIL

DN 40 - DN 600

Nr.	Name des Teils	Material
1	Handrad	Sphäroguss EN-GJS-500-7
2	Sicherungsmutter	Rostfreier Stahl A2-70
3	Unterlegscheibe	Rostfreier Stahl A2-70

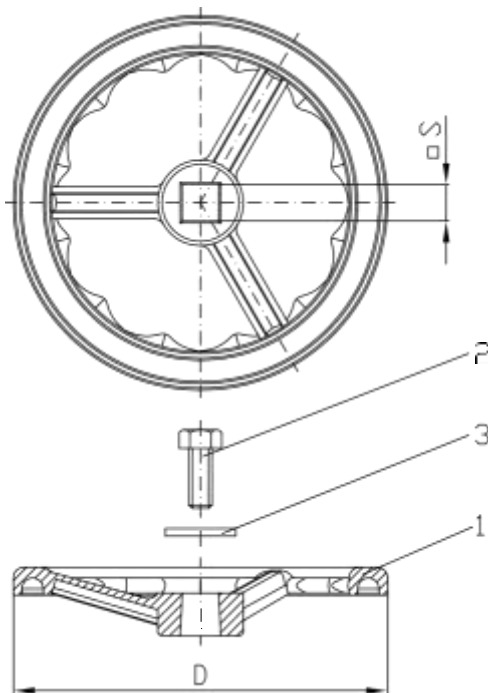

DN	40	50	65	80	100	125	150
D	200	200	250	250	250	300	300
Code	AA2067	AA2067	AA2069	AA2069	AA2070	AA2071	AA2071
Stiel oben quadratisch □S	14	14	17	17	19	19	19
Gewicht [kg]	1,2	1,2	1,2	1,2	1,3	1,3	2,2
DN	200	250	300	350	400	500	600
D	400	500	500	600	600	600	600
Code	AA2072	AA2073	AA2073	AA2074	AA2074	AA2075	AA2075
Stiel oben quadratisch □S	24	27	27	27	27	32	32
Gewicht [kg]	4,1	5,0	5,0	6,0	6,0	7,1	7,1