

# UNDERGROUND FIRE HYDRANT SMART WITH SINGLE SHOUT-OFF

## DN 80



No	Part Name	Material
1	Body	EN-GJS-500-7
2	Stem	SS 420
3	Gland Housing	EN-GJS-500-7
4	Outlet	EN-GJS-500-7
5	Cap Top	EN-GJS-500-7
6	Disc	EN-GJS-500-7 + EPDM
7	Wedge Nut	CW612N
8	Flange Nut	EPDM + PVC
9	Connection Pipe	SS 304
10	Pin	SS 420
11	Brass Ring	CW612N
12	Gland Bush	CW612N
13	Dust Ring	EPDM
14	O-Ring	EPDM
15	O-Ring	EPDM
16	O-Ring	EPDM
17	O-Ring	EPDM
18	Strainer	EPDM
19	Bottom Washer	PTFE
20	Cover	Polypropylene PP
21	Drainage Cover	Polyvinyl chloride PVC
22	Bolt	A2-70
23	Washer	A2-70
24	Bolt	A2-70
25	Pin	A2-70

Flow - Kv value DN 80 [m <sup>3</sup> /h]	
Rd	Kv measured
1000	136
1250	129
1500	122

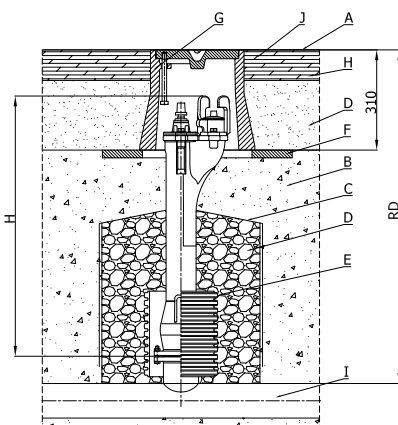
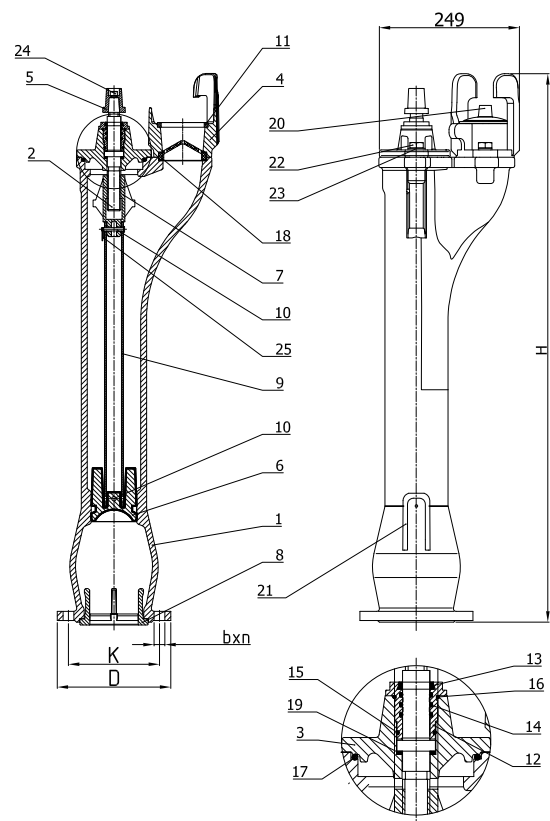

- A - Ground level
- B - Well –established ground
- C - Recommended PE foil or felt
- D- Sand size 4-20 mm
- E - Option: drainage
- F - Base plate
- G - Surface box
- H - Grass
- I - Pipeline
- J - Asphalt

### Dimension:

DN	Code	Rd	H	Connecting flange				Weight kg
				D	K	n	b	
80	AF0652	1000	725	200	160	8	19	31,1
	AF0653	1250	975					38,3
	AF0654	1500	1225					42,1

Rd - recommended construction depth  
H - total height of the hydrant