

# DRY BARREL FIRE HYDRANT SMART DN150 PN16

## AF02-250W-01

No	Part Name	Material
1	Flange Connector	Ductile Iron EN-GJS-500-7
2	Locking Nut	Ductile Iron EN-GJS-500-7
3	Connecting Rod	Steel 1045
4	Locking Nut Gasket	Elastomer EPDM
5	Tray	Ductile Iron EN-GJS-500-7
6	Sealed Rubber Sheet	Elastomer EPDM
7	Drain Hole Spring	Stainless Steel AISI 316
8	Connecting Cylinder	Ductile Iron EN-GJS-500-7
9	Perforated Cylindrical Pin	Steel 1045
10	Connecting Rod Sleeve	Steel 1045
11	Clamp for Connection Tube	Ductile Iron EN-GJS-500-7
12	Main Body on Ground	Ductile Iron EN-GJS-500-7
13	Connector	Bronze C95400
14	Connector Storz 75 with Cap	Aluminum
15	Connector Storz 110 with Cap	Aluminum
16	Upper End Cover	Ductile Iron EN-GJS-500-7
17	Bolt, Nut	Bronze C95400
18	Screw Stem Nut	Bronze C95400
19	Screw Nut Gasket	Bronze C95400
20	Screw Nut Seat	Bronze C95400
21	Bolt, Nut	Steel 1035
22	Connector 100	Bronze C95400
23	Cylindrical Pin	Steel 1045
24	Cover Chain	Gr. B ASTM A283-B
25	Bolt, Nut	Steel 1035
26	Screw Stem	Bronze C95400
27	Screw Stem Bushing	Stainless Steel AISI 304
28	Drain Hole Cover	C95400 + EPDM
29	Seat	Bronze C95400
30	Bolt, Nut	Stainless Steel AISI 304
31	Seat Fixing Plate	Ductile Iron EN-GJS-500-7
32	Bolt, Nut	Steel 1035
33	Annular Tubes	Steel 1045
34	Platen	Ductile Iron EN-GJS-500-7
35	Locking Nut Seat	Ductile Iron EN-GJS-500-7
36	Bolt	Stainless Steel AISI 304
37	Gasket	Elastomer EPDM
38	Adaptor	Ductile Iron EN-GJS-500-7
39	Bolt	Steel 1035

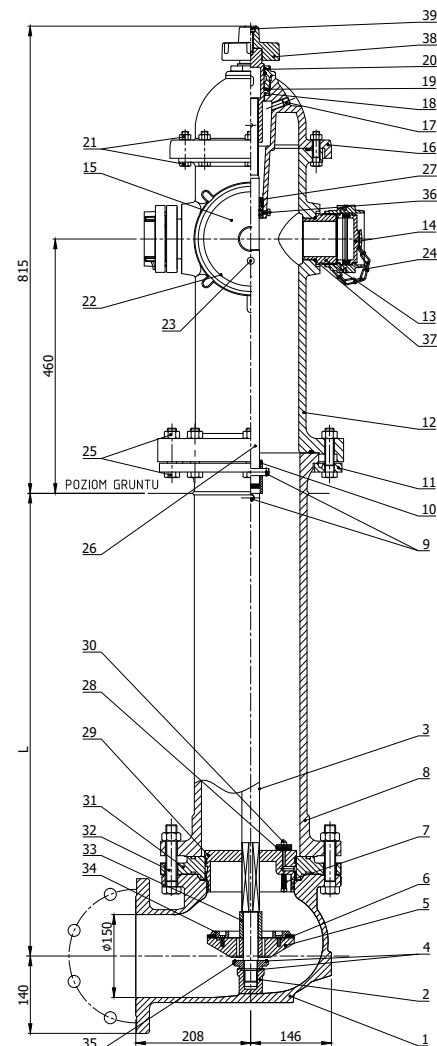

### Dimension:

AF02-250W-01	EN 1092 PN16	AF0798	AF0778	AF0779	AF0780	AF0781	AF0782	AF0783	AF0784	AF0785
L	[inch]	3'	3' 6"	4'	4' 6"	5'	5' 6"	6'	6' 6"	7'
	[mm]	911	1063	1215	1368	1520	1673	1825	1978	2130
Weight (kg)		160	179	196	203	210	225	250	255	265